

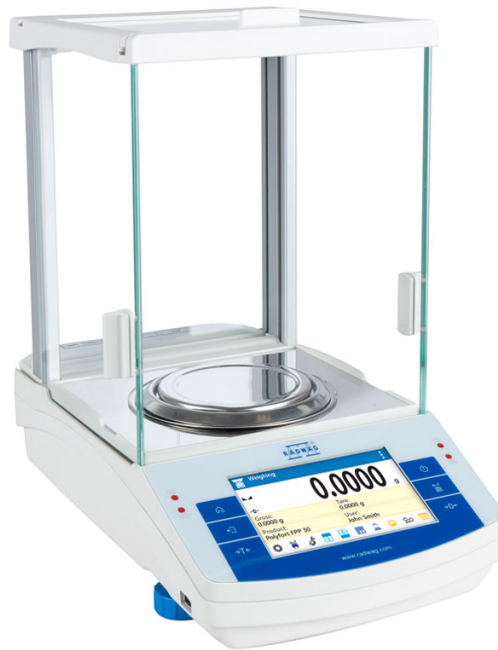

More information on the website
radwag.com/en/info,w1,TS2

AS 220.X2 PLUS Analytical Balance



The drawings, photos and graphics used are for illustrative purposes only.

Functions

-  Autotest
-  Dosing
-  Percent Weighing
-  Parts counting
-  Peak hold
-  Formulation
-  Newton unit measurement
-  Statistics
-  Checkweighing
-  IR sensors
-  Under-pan weighing
-  GLP Procedures
-  Animal weighing
-  Density determination
-  Ambient conditions monitoring
-  Replaceable unit
-  Statistical Quality Control
-  ALIBI Memory
-  Mass for titrator
-  Wi-Fi

Datasheet

Metrological parameters	
Maximum capacity [Max]	220 g
Minimum load	10 mg
Readability [d]	0.1 mg
Verification unit [e]	1 mg

Metrological parameters	
Tare range	-220 g
Standard repeatability [5% Max]	0.06 mg
Standard repeatability [Max]	0.07 mg
Standard minimum weight (USP)	120 mg
Standard minimum weight (U=1%, k=2)	12 mg
Permissible repeatability [5% Max]	0.09 mg
Permissible repeatability [Max]	0.1 mg
Linearity	±0.2 mg
Stabilization time	2 s
Adjustment	internal (automatic)
OIML Class	I
Physical parameters	
Leveling system	semi-automatic - LevelSENSING
Display	5" graphic color touchscreen
Weighing chamber doors	manual
Delivery components	Balance, weighing pan, weighing pan shield, bottom cover, power supply.
Weighing chamber dimensions	190×190×222 mm
Weighing pan dimensions	ø100 mm
Packaging dimensions	490×400×520 mm
Net weight	7.06 kg
Gross weight	8.5 kg
Protection class	IP 43
Relative humidity	40% ÷ 80%
Features of use	
Database capacity	7
Touch-free operation	2 IR Sensors
Communication interface	
Communication interface	RS232 ¹ , 2×USB-A (interchangeable), USB-B, Wi-Fi, Ethernet
Electrical parameters	
Power supply	Adapter: 100 – 240V AC 50/60Hz 0.6A; 12V DC 1.2A Balance: 12 – 15V DC 0.8A max
Power consumption max.	4 W
Environmental conditions	
Operating temperature	+10 ÷ +40 °C
Ambient conditions monitoring	THBR 2.0 System, THBR BOX, THB P, THB W, THB S

Repeatability is expressed as a standard deviation from 10 weighing cycles.

Stabilization time depends on the ambient conditions and the dynamics of weighing pan loading; specified for FAST profile.

¹ Barcode scanners, available as weighing instrument accessory, communicate with the instrument via RS232 interface exclusively.

* Wi-Fi® is a registered trademark of Wi-Fi® Alliance.



Extra payment for verification



Accessories

Antivibration Tables

- SAL/STONE/H Stainless Steel Antivibration Table [WX-001-0079]
- SAL/STONE/C Antivibration Table [WX-001-0078]

Holders for laboratory flasks

- UL-04-1 (AS) Laboratory Holders [WX-001-0033]
- UL-03-1 (AS) Laboratory Holders [WX-001-0032]

Power Adapters

- ZR-04/1 Powerbank [WX-015-0329]
- ZR-03/1 Powerbank [WX-015-0319]

Barcode scanners

- PD9330-AR Barcode Scanner [WX-006-0030]
- PM9300-D Barcode Scanner [WX-006-0033]
- LS2208 Barcode Scanner [WX-006-0005]
- PD9531 Barcode Scanner [WX-006-0046]
- DS2208 Barcode Scanner [WX-006-0036]
- PM9300 Barcode Scanner [WX-006-0031]
- PM9300-DK Barcode Scanner [WX-006-0034]

Cigarette lighter receptacle power supply cables

- K0047 Car lighter 12V cable [WX-013-0034]

Density determination KIT

- KIT 85 Density Determination Kit [WX-001-0001]

USB cable (scale - printer)

- PT0238 USB Cable Type A-B [WX-013-0056]

Professional weighing table

- PSW Professional Single Weighing Workstation [WX-001-0020]
- PSW/DUAL Professional Dual Weighing Workstation [WX-001-0402]

Holders for test tubes and filters

- UL-02-1 (AS) Laboratory Holders [WX-001-0031]
- UL-01-1 (AS) Laboratory Holders [WX-001-0036]

Workstation for Pipettes Calibration

- SDKP Workstation for Pipettes Calibration [WL-101-0181]
- SDKP DUAL Workstation for Pipettes Calibration [WL-101-0173]

THBR 2.0 System - Ambient Conditions Monitoring

- THBR Box Ambient Conditions Recorder [WX-016-0163]
- THB W Sensor [WX-016-0162]

Displays

- WD-6 LCD Display - Plastic Housing [WX-002-0030]

Protective cover for balances

- Protective Cover for X2 PLUS / R2 PLUS Balance [WX-001-0433]
- Protective Cover for X2 Balance [WX-001-0094]
- Fabric Dust Cover for AS PLUS Balances [WX-001-0179]

Weighing dishes

- Weighing dishes for ultra-microbalances, microbalances and analytical balances [WX-001-0429]

Antistatic ionizer

- DJ-04 Antistatic Ionizer [WX-001-0097]

Receipt Printer

- RTP-UEW80 Radwag Thermal Receipt Printer (USB + Ethernet + WiFi) [WX-007-0118]
- RTP-RU80 Radwag Thermal Receipt Printer (RS232 + USB) [WX-007-0119]

RS 232, RS 485 cables

- P0108 Cable [WX-013-0003]
- PT0443 Cable [WX-013-0229]
- P0108.5 Cable [WX-013-0161]

Additional modules

- 21 CFR Part 11 Compliance Module (X2) [WX-001-0187]
- RES Radwag Extended SI Module (X2) [WX-016-0265]

Under-pan weighing

- Under-pan Weighing Rack for AS and PS Balances [WX-002-0111]
- Under-Pan Weighing Hook (XA, AS, PS) [WX-015-0325]

RS 232 cables (scale - printer)

- P0151 Cable [WX-013-0002]

RS 232 – RS 485 Converter

- KR-01 Converter [WX-004-0021]

Software

- RAD Key [WX-010-0005]
- THB-R [WX-010-0122]
- R-Lab [WX-010-0080]
- E2R Weighing Records [WX-010-0038]

- LabVIEW "Radwag Balances & Scale" Driver [WX-010-0105]
- Alibi Reader [WX-010-0114]
- RADWAG Development Studio [WX-010-0104]
- R-Barcode [WX-010-0109]

Device dimensions

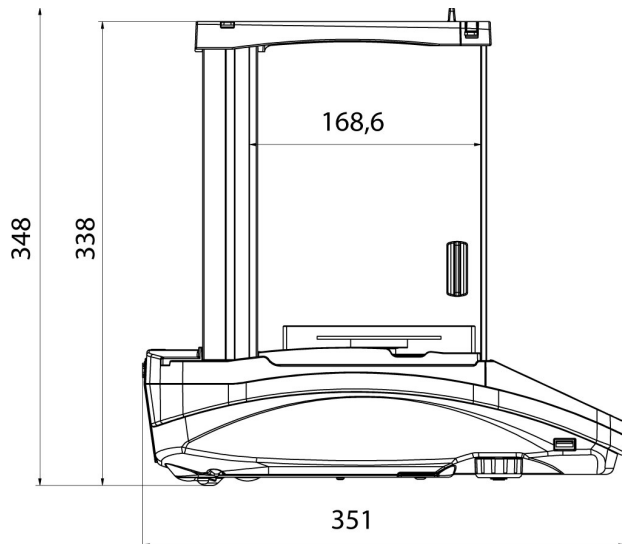
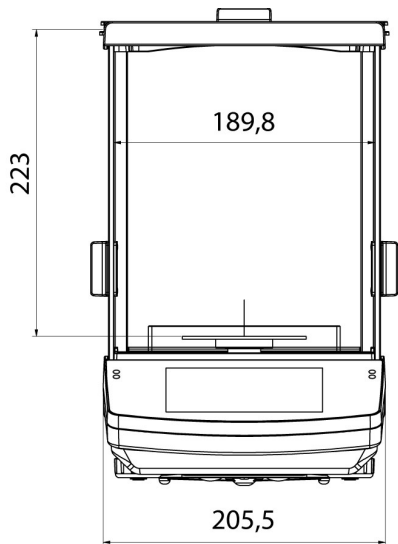

AS X2 PLUS, $d = 0.01 \text{ mg}$

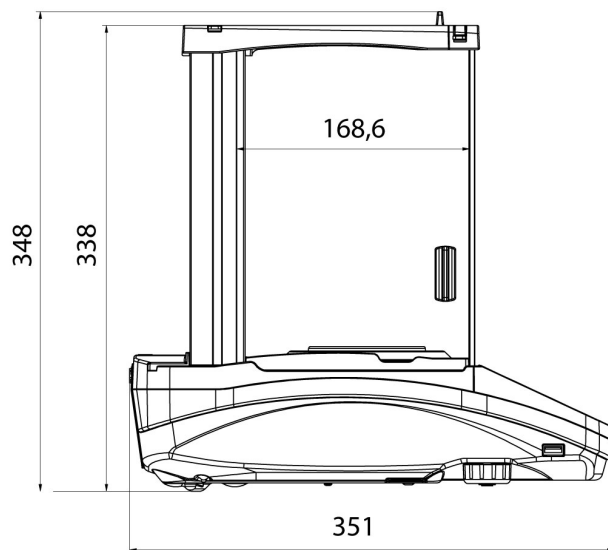
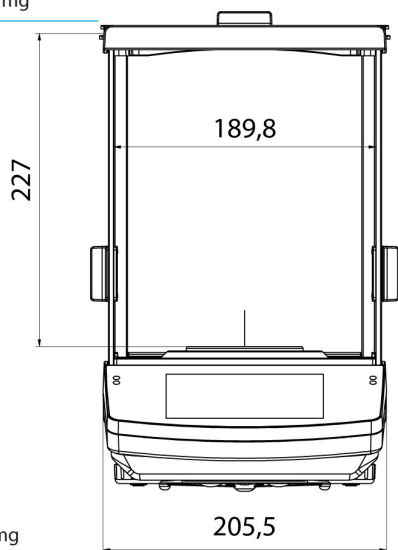

AS X2 PLUS, $d = 0.1 \text{ mg}$